

THE USAGE OF ARTIFICIAL NEURAL NETWORKS IN HYDRODYNAMIC ANALYSIS OF FLOATING OFFSHORE PLATFORMS

Said Mazaheri¹

1-Assistant Professor, Maritime Transport & Technology Group, Transportation Research Institute

Abstract

Floating offshore structures, particularly floating oil production, storage and offloading systems (FPSOs) are still in great demand, both in small and large reservoirs, for deployment in deep water. The prediction of such vessels' responses to her environmental loading over her lifetime is now often undertaken using response-based design methodology, although the approach is still in its early stages of development. Determining the vessel's responses to hydrodynamic loads induced by long term sea environments is essential for implementing this approach effectively. However, it is often not practical to perform a complete simulation for every 3-hour period of environmental data being considered. Therefore, an Artificial Neural Networks (ANN) modelling technique has been developed for the prediction of FPSO's responses to arbitrary wind, wave and current loads that alleviates this problem. Comparison of results obtained from a conventional mathematical model with those of the ANN-based technique for the case of a 200,000 tdw tanker demonstrates that the approach can successfully predict the vessel's responses due to arbitrary loads.

Keywords: seakeeping, floating offshore platforms, artificial neural networks

Introduction

Methods for calculating the maximum responses of a turret-moored FPSO subjected to arbitrary wind, current and wave loads for an N-year life period, which is essential for mooring system design, are still being developed. Standing, Thomas et al. [1] showed that by using response-based methods the 100-year maximum resultant excursion of an FPSO can be reduced to about 75% to 80% of the maximum excursion predicted using a traditional collinear combination of a 100-year wind, a 100-year current and a 100-year wave. However, it should be noted that in some cases other combinations of environmental loads e.g. smaller and steeper waves, may create larger

excursions than the combinations of the 100-year collinear values. The results obtained by Incecik, Bowers et al. [2] for a specific semi-submersible are a good example of a case where the severe mooring loads did not occur when wind, wave, and current loads were collinear and acting at their maximum design values for a N-year life period. For these reasons the response-based calculation procedure can be expected to yield more accurate results than the traditional method. In order to make the response-based method more practical for real cases an artificial neural network based model has been developed.

The methodology of a response based approach applied to a turret-moored

FPSO is presented in the flow chart shown in Fig. 1. The procedures involved entail the following tasks:

- 1) Building up a mathematical model in order to determine the loads and motions of a turret-moored FPSO due to wind, current, and waves. This model should take into account the nonlinearities of the loads as well as their direction.
- 2) Obtaining the vessel's responses by running the mathematical model over a reasonable period of environmental data, for example 5 years.
- 3) Setting up an artificial neural network (ANN) that has been trained and cross validated using sufficient data obtained from the mathematical model to ensure an accurate representation of vessel responses as a function of environmental variables.
- 4) Using the ANN to generate long term vessel responses (e.g. using 25-year met-ocean data) and analysing them statistically to predict the vessel's maximum excursion over an N-year life period.

It can be seen that the development of the vessel's mathematical response model and the ANN model are the most crucial parts of the response-based methodology. Details of the mathematical model used for generating the vessel responses have been reported elsewhere [3, 4]. In what follows, a brief overview of the response mathematical model will be presented but attention will be focussed chiefly on the ANN model. Finally, the results obtained from an ANN based model applied to the case of a 200,000 tdw FPSO will be compared with the results obtained using a traditional response mathematical model.

Nomenclature

- L : length between perpendiculars
 F : activation function

- X : input vector
 Y : output vector
 f : non-linear function
 g : gravitational acceleration
 k : mooring stiffness
 α : wind direction
 β : current direction
 δ : water depth/draft
 γ : wave direction
 ϕ : output function
 ω : wave frequency
 H_s : significant wave height
 $U_{current}$: current velocity
 V_{wi} : wind velocity
 x_i : input parameter
 y_i : output parameter
 W_{ij} : weighting factor

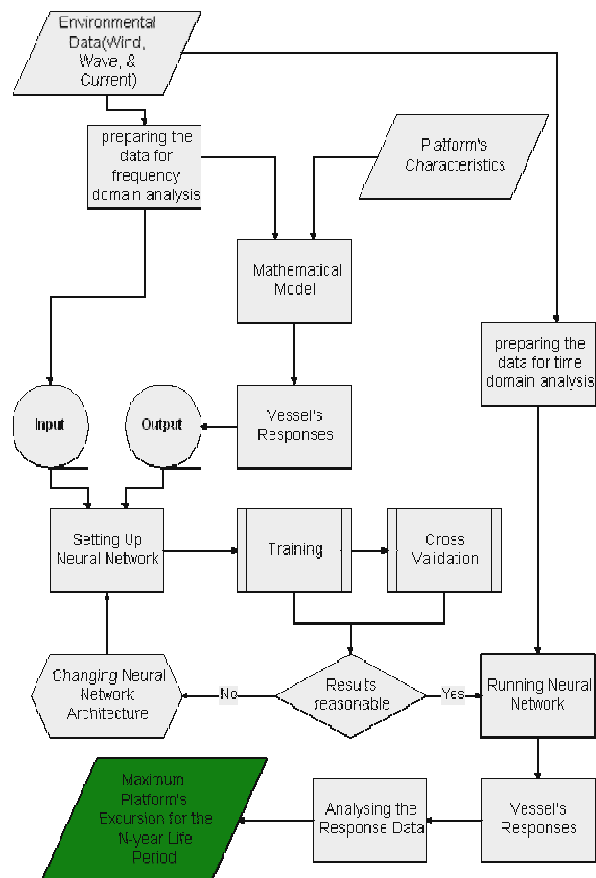

Figure 1- The flowchart of response-based methodology

Mathematical response model

The mathematical response model (SAMRES)[5] involves the calculation of the 1st and 2nd order loads and motions of an FPSO subjected to arbitrary wind, current and waves. The model accounts for the effects of shallow water and also of the vessel's weathervaning.

1st order loads and motions

Strip theory has been employed for calculating 1st order wave loads and motions. The effects of finite depth and current have been considered in deriving the first order wave loads and motions. Also, in deriving wave induced surge load the influence of the vessel's lateral curvature has been accounted for and the model validated by comparing results with those obtained using the surface integration method and Oortmerssen's 3-D source technique[6]. The volume integration method was shown to give very good agreement with the 3-D source technique.

A simple drag force formula has been used in calculating the steady wind loads in which the drag force coefficients have been selected from the API standard [7].

For calculating current induced loads, the approximate drag force formula has been used in surge mode. However, the sectional drag force has been integrated over the vessel's length in calculating the transverse force. Moreover the effects of the Munk moment and the turret mooring system have been taken into account in the calculating current induced yaw moment.

A mathematical response model, based on the above, has been written in MATLAB and the program has been executed for a particular FPSO whose principal characteristics are listed in Table 1. The results obtained for the loads and responses have been compared with those from a 3-D source technique.

The lateral RAOs for the vessel in head seas are shown in Fig. 2.

Table 1- Particulars of 200,000 tdw FPSO

Length between perpendiculars	310 m
Breadth	47.20 m
Draft	18.90 m
Volume of displacement	235,000 m ³
Block coefficient	0.85
Mid-ship section coefficient	0.995
Prismatic coefficient	0.855
Distance of cg to mid-ship section	6.61 m
Height of centre of gravity	13.32 m
Meta-centric height	5.78 m
Longitudinal radius of gyration	77.50 m
Transverse radius of gyration	17.00 m

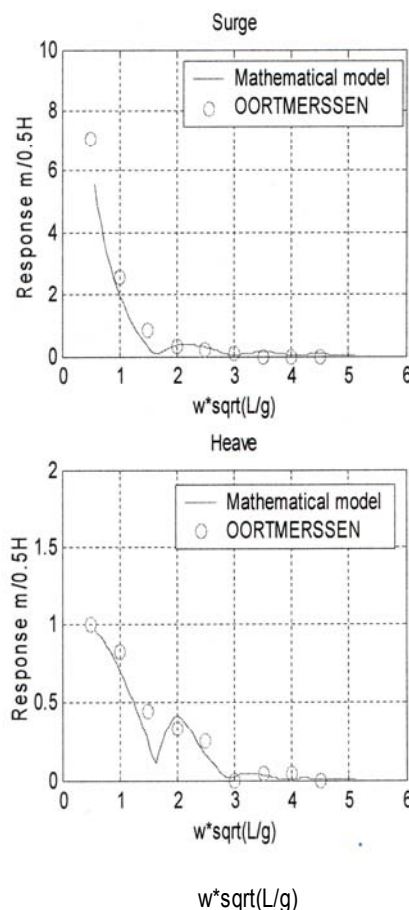

Figure 2- Motion transfer functions in surge, sway and heave modes, $\gamma = 0$

From the results the following can be observed:

- The data obtained from the mathematical model correlate well with those obtained by Oortmerssen who used a 3-D boundary integral approach.
- The motion transfer functions calculated by the two approaches are in particularly good agreement in the surge, sway and heave modes.
- The results show that in the present instance the strip theory approach represents a viable alternative to the 3-D boundary integral technique, particularly since lateral loads and motions are the subject of the calculation.

2nd order loads and motions

Although the effects of wave direction, frequency and the waterline shape of the floating structures on the wave mean drift force formula have been considered by several authors, a general formula taking them all into account was not found. For present purposes, Faltinsen's wave drift force formula [8] has been modified by adding a finite draft coefficient. The results obtained from the resulting formula, which is wave frequency dependent, compare favourably with Helvacioğlu's experimental data[9] at sufficiently high wave frequencies (Fig. 3). In addition, the influence of the current on the wave mean drift force has been taken into account by considering the current coefficient derived from the ship added resistance formula. This approach predicts that the presence of current can increase the mean drift force by up to 50 percent at particular wave frequencies, although it does not account properly for the effects of the body geometry. However, the following general

conclusions can be drawn from the results [4]:

- The mean drift force loads in irregular waves are smaller than those in regular waves. The results obtained for a 200,000 tdw tanker showed that the ratio between the mean drift force in irregular waves to that in regular waves would be between 5 to 15 percent for a 5m significant wave height.
- The formula for the calculation of the wave drift damping has been extended to cover high wave frequencies as well as low wave frequencies. The results compared with asymptotic formula showed good agreement in high frequencies band (Fig. 4).
- The low frequency motion of a 200,000 tdw tanker has been calculated by a mathematical model written in MATLAB and the results showed that the effect of 2 m/s current could increase the vessel's surface motions by up to 50 percent. However, the effect of current on the slowly varying yaw motion is opposite and some decreases can be seen.

Wind can also create slowly varying motions and in this regard both mean wind force and wind gust force must be considered. In this study the modified Harris wind gust spectrum has been adopted and the 200,000 tdw tanker's motions for a 30 m/s average wind speed have been calculated as shown in Table 2. It can be concluded that second order wind forces can play a significant role in vessel's surface responses.

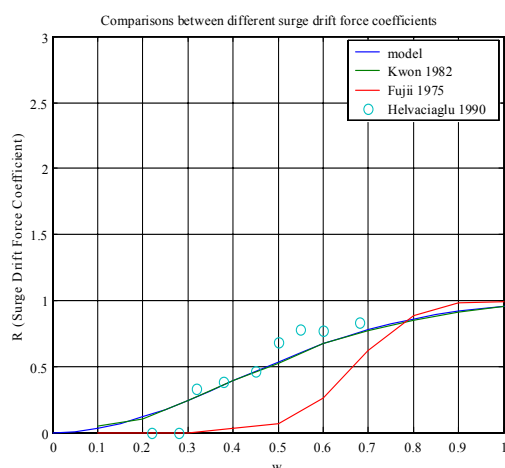

Figure 3 - Surge drift force coefficients

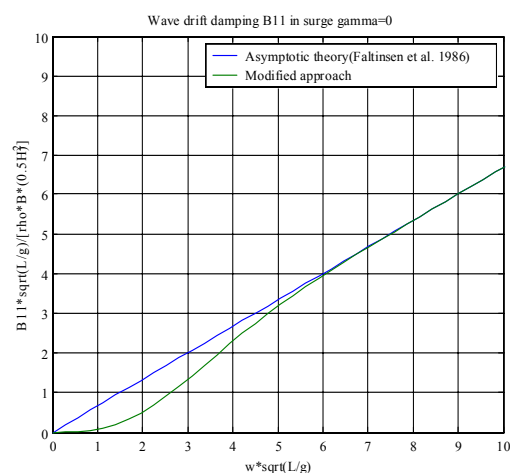

Figure 4- Wave drift damping in surge mode

Weathervaning effects

The response model has been shown to provide a good description of the weathervaning effects observed for a turret-moored FPSO subjected to wind, wave and current loads. It is therefore possible to analyse the phenomenon in terms of the relative contributions made by the first and the second order components of the environmental loads. For example, the effect of the first order wind load on the 200,000 tdw tanker subjected to 30 m/s wind speed is to increase its wind-induced rotational moment by up to 50 percent in its ballasted condition as compared to that of its loaded condition. The deck

structures in this example contribute up 30 and 10 percent of the total wind-induced rotational moment in the ballasted and loaded conditions respectively. The vessel's maximum rotational velocity occurs when the direction of the current is perpendicular to its heading angle.

Calculation of the equilibrium angle for the vessel subjected to different sea states showed that the first order wave load effect is dominant although the current can have a significant effect. Current fluctuations are a second order effect whose influence can be shown to be very small. Therefore, the second order current effect on the vessel's weathervaning has been neglected.

Analysis of the second order effects of wind and wave loads on the 200,000 tdw tanker showed that they are responsible for fluctuations of a few degrees. Finally, it has been observed that the vessel can be shifted from one of her equilibrium angles to the other if the initial heading angle is such that the wind and wave forces act from aft of the vessel.

Table 2-Vessel's responses due to wind force

Wind Angle	Wind Speed (m/s)	Area Against Wind	Mean Offset (m)	Mean square values (σ _x ²)	Significant values (σ _x)	Total Response (m)	Response Mode
α =0	30	850	1.15	0.32	1.13	1.47	Surge
α =90	30	5580	7.53	13.7	7.4	21.23	Sway
α =45	30	850	0.58	0.10	0.64	0.68	Surge
α =45	30	5580	3.8	4.46	4.22	8.26	Sway

Artificial Neural networks (ANN) Model

The development of Artificial Neural Networks (ANN) has been inspired by the nervous system of the human brain.

ANNs are comprised of many basic processing elements connected in a specified parallel structure. Each processing element, which is called a neuron, is described by a non-linear differentiable function of preferably sigmoidal shape. Associated with each interconnection, there is an adjustable parameter weight that changes according to a certain learning rule.

Depending on their structures, they can be broadly categorised as either "Static" or "Dynamic" networks. In static networks the input signal flow is directed to the output with no information feedback path while in dynamic networks, the output from each neuron or network is fed back as additional input.

Static ANNs have the capability of storing data during a "learning" process and then reproducing this data during a "recall" process. Their interpolation, and in some cases extrapolation, capability is very powerful particularly when mapping a multi-dimensional input data space to a multi-dimensional output data space. It is common for empirical data to be used directly for marine design and analysis. Thermodynamics, fluid dynamics and heat transfer tables and charts are iteratively used, and provide data sets, which cannot be accurately modelled because they are highly non-linear and multi-dimensional. The non-linear functional mapping properties of ANNs, and their capability to learn a new set of input patterns without significant disturbance to the previous structure, are also important factors which make them particularly useful for the modelling and identification of dynamic systems.

ANN Technology

ANNs are widely used as nonlinear, non-physical and universal modelling tools [10]. Recurrent or dynamic ANNs

are capable of capturing systems' dynamics and can uniquely provide inverse models of dynamic time-variant systems [11], which are of great importance in the design of adaptive control systems. Their rapid developments during the last two decades, has resulted in the introduction of many different classes of ANNs, such as Neocognitron, RBF, recurrent, cooperative, Hybrid, and Sigma-Pai ANNs, each one tailored to perform best in an individual task. The network of choice for most pattern recognition problems is the multi-layered feed forward network. There are several network types, which are useful for pattern autoassociation, allowing a complete pattern to be reconstructed when only a partial or degraded pattern is used as input. The Hopfield/Tank and the Brain-State-in-a-Box (BSB) networks are of the most common pattern associators. They both possess a single (unified) input/output layer, which work well on small pattern sets, but cannot store large numbers of patterns without interference.

ANN architectures of different types, trained either off-line or on-line with different learning algorithms, have been proposed and used for the modelling and control task of dynamic systems. For implementation within modelling and motion predictions of marine dynamic systems the following properties of ANNs are important.

- **Applicability to Nonlinear Systems:** it has been shown [11] that a feed-forward ANN with at least one hidden layer is capable of approximating any nonlinear function once enough training has been provided. Due to this capability, they are also easily capable of providing reverse (effect-to-cause) models of any nonlinear system.

•Parallel Distributed processing and Hardware Implementations: ANNs have inherent parallel architecture, which could lead to parallel hardware implementations. These implementations also have an advantage of having, in general, a high degree of fault tolerance and high processing speed due to simplicity of their connections.

•Learning: ANNs can be trained using past recorded data (offline learning) or current data (online learning).

•Applicability to Multivariable Systems: ANNs are, by definition, multi-input multi-output entities and this naturally leads to their application to multivariable systems such as power plants.

•Speed of response: Trained ANN models are much faster by far than physical models since they do not need to perform any iterative calculations and/or search for any parameters. This could provide an online platform for live data processing and analysis.

ANNs can generally represent the mapping of multi-dimensional input/output data sets as:

$$f : X \rightarrow Y \quad \text{Eq. (1)}$$

f is a non-linear function, $X=(x_1,x_2,\dots,x_n)$ is real input vector, $Y=(y_1,y_2,\dots,y_m)$ is real output vector, Fig. 5. ANNs are best used for interpolation, but in some cases have also been demonstrated to yield valid extrapolations.

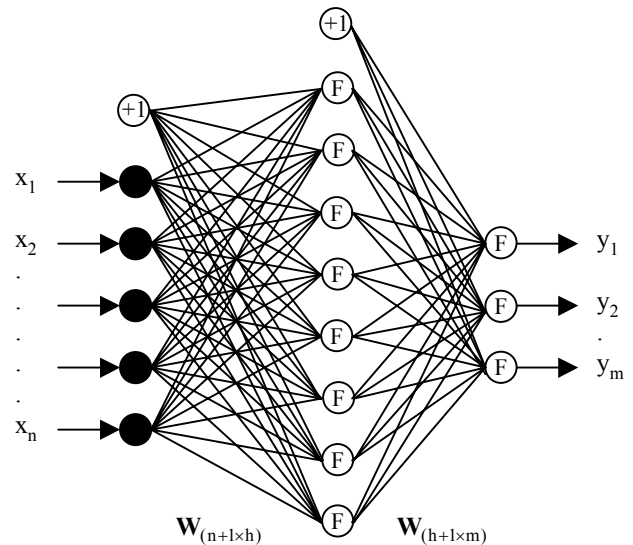

Figure 5 - General structure of an Artificial Neural Network

Model input/output selection

Before selecting the ANN's structure, a set of input/output data should be obtained. These data in the context of the seakeeping analysis of an FPSO are the met-ocean parameters as input and the vessel's excursion as output. In this regard six met-ocean parameters have been used i.e. wave height and direction, wind speed and direction, and current speed and direction. These data have been randomly selected in a systematic fashion to cover a wide range of sea states. In Table 3 a sample of those input data has been presented. Meanwhile, the vessel's excursions; the surge, sway and total vessel's offset associated with each series of input data have been calculated. This calculation is based on the SAMRES model, which utilises the hydrodynamic equations based on the theories described in previous sections. The SAMRES model has been implemented for a series of almost one thousand sets of input data. This was a time consuming task since about 2 hours are required to get the response results for each set of data. Some typical results obtained from SAMRES are presented in table 2.

The ANN structure

The ANN structure plays a significant role on mapping out the input data onto the output neurons but, unfortunately, there are no well-defined rules for building up an ANN structure for a particular purpose and data set [12]. For every new problem the network structure must be designed by trial and error [13]. In the present case, taking into account the nature of the input and output data displayed in Table 3, a (6-10-3) multilayer feed forward network, which has one hidden layer containing 10 neurons, has been selected (Fig 6). It is clear that the number of neurons in the input and output layers has been chosen according to the number of input and output parameters. The input parameters are the met-ocean variables as shown in Fig. 6 and the vessel's excursions, namely surge, sway and the total vessel's offset, are the output parameters. It will be noted that the total vessel's excursion is dependent on surge and sway and could be ignored in the ANN model. However, it was found that the neural networks with three outputs responded better to the training process than those with two. For this reason the third output was retained as a redundant output for future development. The number of neurons in the hidden layer has been selected on a trial and error basis in both the training and cross-validation procedures. The number of neurons in the hidden layer was initially started with 4 and subsequently increased to 10, where the mean square error is considered to be sufficiently small. The trend of the mean square error for different numbers of neurons in the hidden layer, both in the training and cross-validation procedures, has been plotted in Figure 7.

Table 3 - The met-ocean parameters and relevant vessel's excursion ($\delta = 1.2$, $k = 500$ KN/m)

V_{Wi} (m/s)	α	H_s (m)	γ	U_c (m/se)	β	Surge (m)	Sway (m)	Excur. (m)
32	136	2	73	1	233	1.09	4.04	4.18
10	206	3	148	1	115	0.13	1.04	1.05
14	31	4	321	1	40	0.48	3.87	3.90
25	53	8	68	2	242	9.52	1.06	9.58
23	124	5	88	2	265	2.06	5.61	5.98
25	103	3	228	2	321	0.84	0.01	0.84
12	224	4	280	1	343	0.46	1.13	1.22
21	302	2	229	1	8	0.41	0.00	0.41
28	139	5	309	1	59	1.25	41.18	41.20
20	206	7	248	2	76	6.07	0.52	6.09
33	329	3	298	2	159	0.27	68.15	68.15
33	177	2	61	1	232	1.49	0.62	1.61
24	228	8	307	2	262	4.57	24.80	25.22
26	179	8	341	1	157	7.56	21.70	22.97
13	180	6	4	1	65	2.05	0.58	2.13
20	179	4	315	1	210	0.56	13.68	13.69
25	150	5	125	2	331	1.77	26.30	26.36
11	204	6	326	1	43	2.16	1.53	2.64
34	166	4	237	2	197	1.96	0.40	2.00
25	254	3	211	1	120	0.77	0.15	0.79
16	243	2	162	2	40	0.05	4.67	4.67
21	160	5	302	2	251	0.86	15.37	15.39
35	282	7	240	2	40	7.42	1.01	7.49
16	302	5	97	2	138	0.81	2.75	2.86
25	76	3	298	1	56	0.19	26.93	26.94

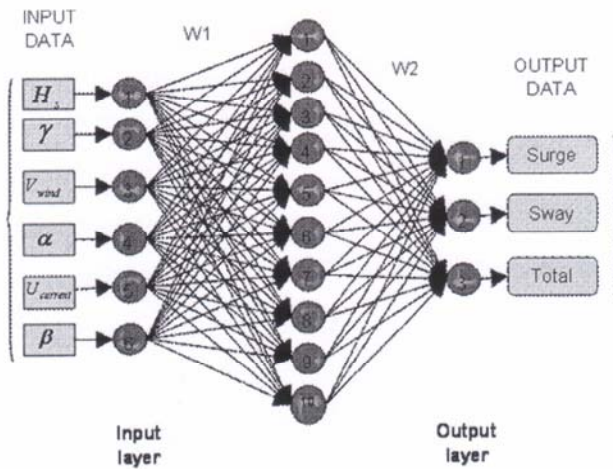

Figure 6-A multi-layer feed forward network

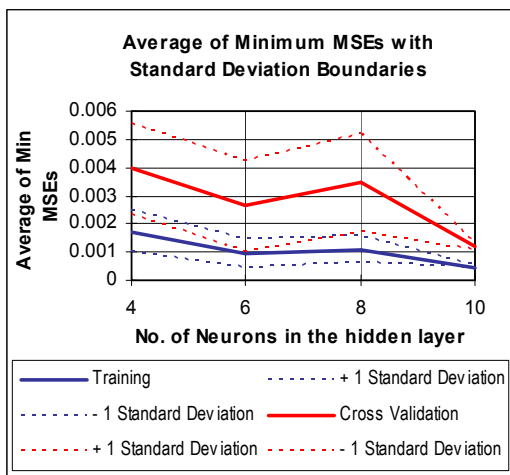

Figure 7- Average of minimum MSEs

Training the designed ANN

The training of the ANN has been carried out so that the network output parameters obtained by the ANN model have a good correlation with the output parameters determined by the mathematical model (SAMRES). The performance of the ANN depends heavily on the number of neurons in the hidden layer and the amount of data and the number of iterations used in the

training process. The trend of increasing accuracy with increasing number of neurons and increasing number of iterations is shown in Figure 8. The task was carried out by systematically increasing the amount of data and monitoring the mean square error (MSE). The number of training iterations used for the process was set at 5000 and an acceptable accuracy was achieved with 10 hidden neurons and using 340 data sets. With the appropriate number of iterations used in the training task the designed ANN mapped out the desired output perfectly from the input data (met-ocean variables). In Fig. 10 the desired surge has been plotted against the actual network surge and similarly the results for sway can be seen Fig. 11. The flowchart of training procedure including the approximate time needed for each task to be done is illustrated in Fig. 12.

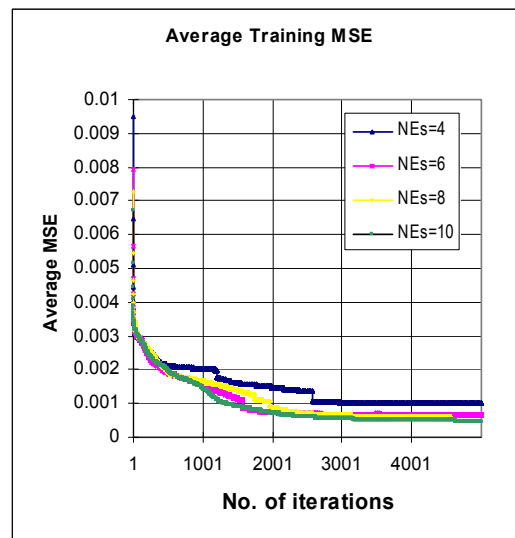

Figure 8 - Average MSE in training procedure

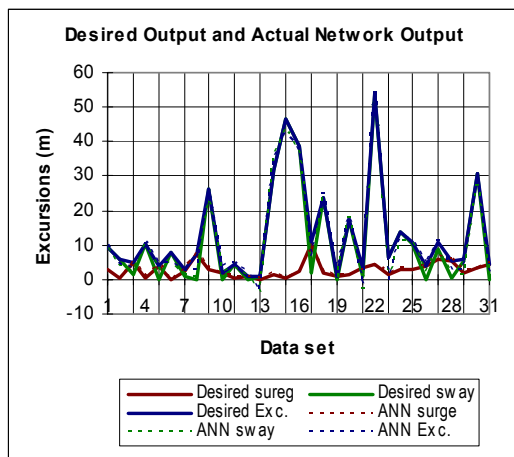

Figure 9-Desired and the ANN outputs in testing procedure

Validating the designed ANN model

The proposed ANN model must be tested with some other data that has not been used in the training procedure. For this purpose, 30 sets of data were selected. These sets were generated by the same procedures as those data sets used for training. The desired output (test data) has been plotted together with the ANN output and the results can be seen in Fig. 9. The regression coefficients for the vessel's surge, sway and total excursions are 0.98, 0.99 and 0.98 respectively. The results show that the designed ANN model can simulate the surface motions of a 200,000 tdw vessel subjected to arbitrary sea loads predicted by the hydrodynamic mathematical model (SAMRES) with a very high degree of accuracy.

concluding remarks

Response-based methodology has been used by industry to calculate the extreme responses of floating offshore platforms since the mid 90s but in some

respects it is still in its early stages of development. A response based methodology is potentially of great interest for the design of FPSOs but it suffers from the drawback of being so computationally demanding, if based on appropriate long term data, as not to be viable for many practitioners. ANNs provide a means of overcoming this problem. For example, the elapsed time that would be taken to calculate the responses of the 200,000 tdw FPSO for 1000 sets of met-ocean data using the SAMRES model can be reduced from 80 days to less than a minute if carried out instead using the ANN based methodology on the same (rather modest) machine. This represents an enormous saving even taking into account the processing required to train the ANN.

The proposition that response based design could be used routinely for design if they incorporate ANN models, rests on the robust performance of the ANNs and their ease of use. In the example of the 200,000 tdw turret moored FPSO chosen for the present study, comparison of the results obtained from the designed ANN model with those from the SAMRES model showed that good correlations are achieved. This means that the designed ANN model can successfully predict the vessel's responses due to arbitrary wind, wave and current loads. Therefore the designed ANN model can be a practical replacement of SAMRES model for response-based technology approach to calculate the extreme vessel's response over her lifetime.

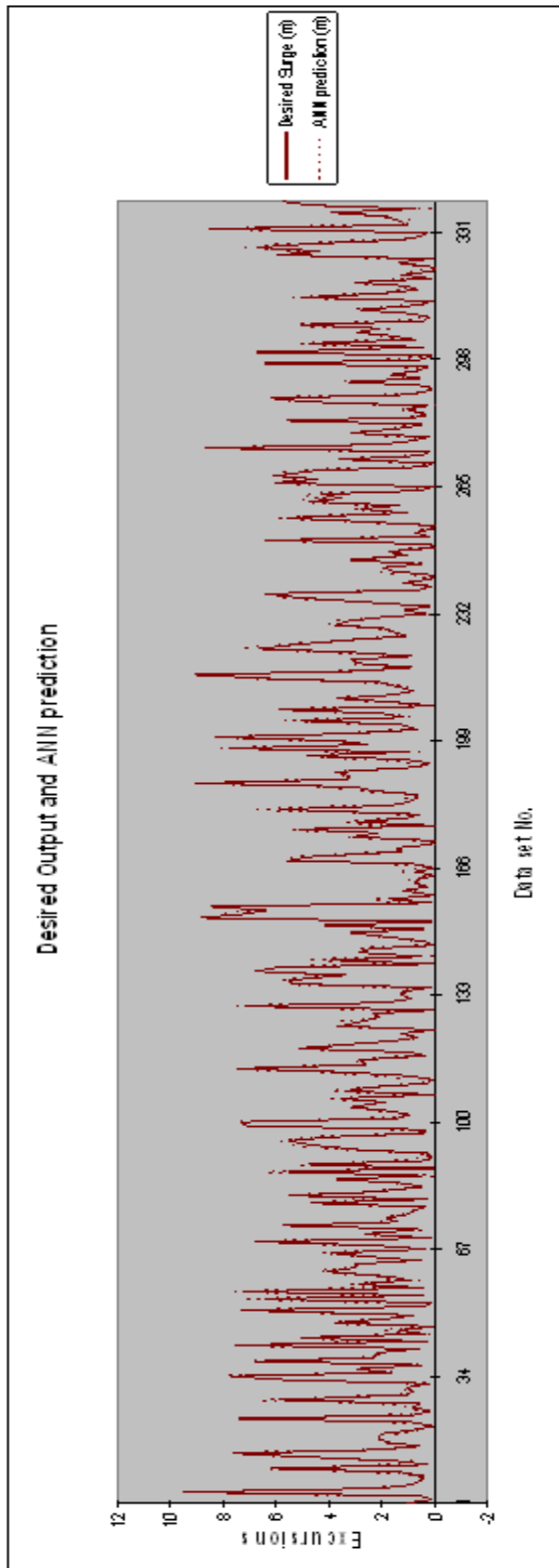

Figure 10-Desired and the ANN excursions in Surge mode

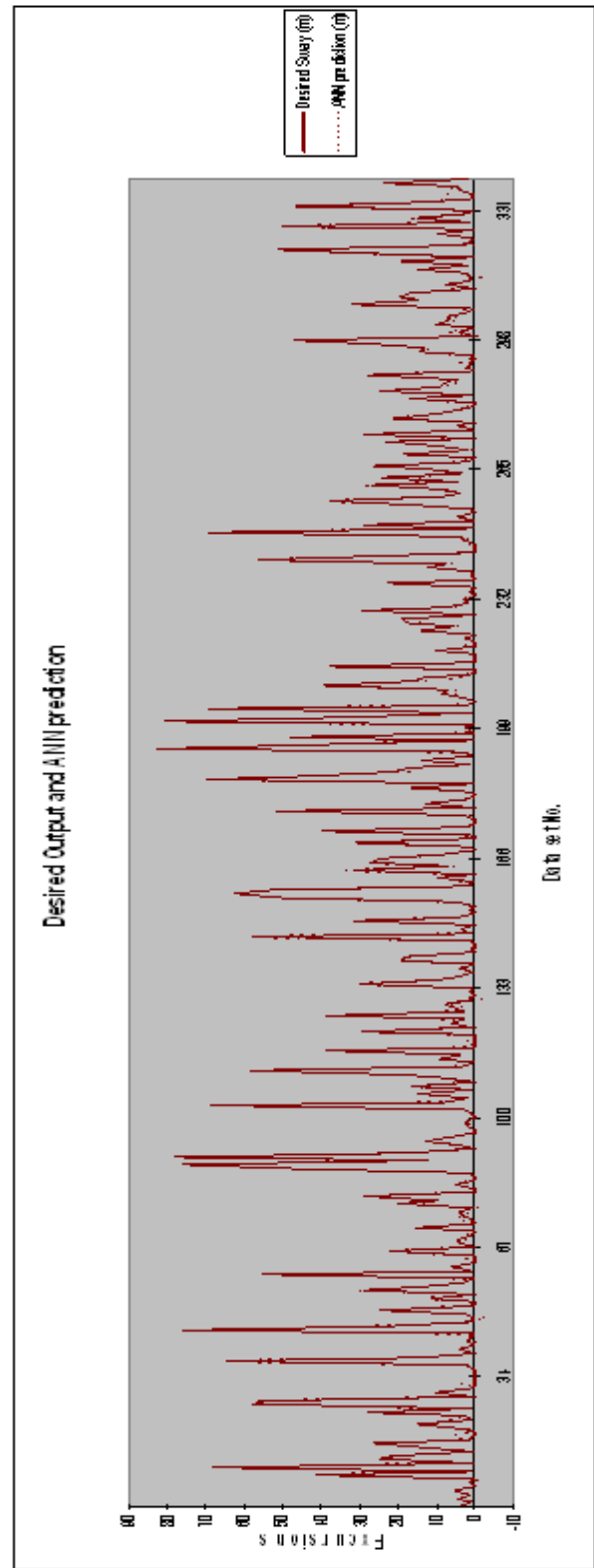

Figure 11-Desired and the ANN excursions in Sway mode

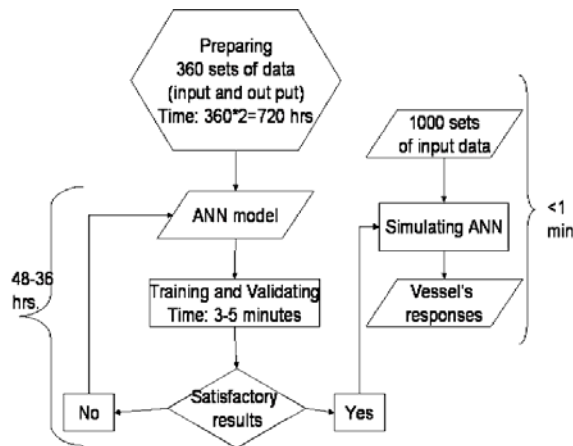

Figure 12-Training and simulating tasks of the ANN model along with the required time for doing those tasks

References

- 1-Standing, R.G., et al. The Development of a Response-Based Design Methodology for FPSOs in Exposed Locations. in Conference on Progress in Economics, Design and Installation of Moorings and Anchors to Realise the potential of Deep Water fields. 1997. Aberdeen.
- 2-Incecik, A., et al., Response-based extreme value analysis of moored offshore structures due to wave, wind, and current. *Journal of Marine Science and Technology*, 1998. 3: p. 145-150.
- 3-Mazaheri, S. and A. Incecik. Response-Based Analysis of Floating Offshore Structures in Persian Gulf. in 4th International Conference on Coast, Ports, and Marine Structures. 2000. Bandar Abbas, Iran.
- 4-Mazaheri, S. The development of second order loads and motions of an FPSO as a part of response-based approach. in 1st PG Research Conf. 2002. Newcastle University: Dept. of Marine Tech.
- 5-Mazaheri, S., Response-based analysis of an FPSO due to arbitrary wind, wave and current loads, in School of Marine Science & Technology. 2003, Newcastle University: Newcastle upon Tyne. p. 255.
- 6-Oortmerssen, G.V., The Motions of a Moored ship in Waves, in Ship Model Basin. 1976, TU Delft: Wageningen. p. 138.
- 7-American Petroleum Institute., Recommended practice for planning, designing, and constructing fixed offshore platforms : load and resistance factor design. 1th ed. 1993, Washington, DC: American Petroleum Institute. 191.
- 8-Faltinsen, O.M., Sea Loads on Ships and Offshore Structures. Cambridge ocean technology series. Vol. 1. 1990, Cambridge: Cambridge University Press. 328.
- 9-Helvacioglu, I.H., Dynamic analysis of coupled articulated tower and floating production system, in Marine Technology. 1990, University of Newcastle: Newcastle Upon Tyne. p. 267.
- 10-Mesbahi, E. and M. Atlar. Applications of Artificial Neural Networks in Marine Design Modelling. in International Conference on Artificial Intelligence on Marine Applications. 1998: Proceedings of AIOMA'98.
- 11-Mesbahi, E. and A.P. Roskilly. A Model Reference Neural Adaptive Controller (MARNEC) for time-varient systems with uncertainties. in International Conference on Control and Applications. 1998: Proceedings of LASTED.

12-Haykin, S., Neural Networks:A Comprehensive Foundation. 1999, New Jersey: Prentice-Hall, Inc. 842.

13-Mesbahi, E., Artificial Neural Networks for Sensor Validation, Fault Diagnosis, Modelling and Control of Diesel Engines, in Dept. of Marine Technology. 2000, Newcastle University: Newcastle upon Tyne.